

STANDARD CONSTRUCTION

FRAME: 18-GA. galvanized steel, channel or flanged type.

BLADE: 18-GA. galvanized steel. Blades approximately 2 1/8" on centers.

SCREEN: (When indicated)
1/2" mesh, 19-GA. galvanized steel (.041").

CONSTRUCTION: Riveted and/or welded for maximum service.

OPTIONS

Frames and Blades of other gauges

Other materials - Stainless steel, Copper, Aluminum, etc.

Finishes - Enamels, Epoxies, etc.

Screens - Insect screen 1/16" aluminum mesh.

- or- 1/2" flattened aluminum, .051",
- or- 1/4" sq. mesh, 18-GA galvanized steel, .047",
- or- 1/2" sq. mesh, 18-GA stainless steel, .047",
- Others available.

NOTES

1. Nominal deductions will be made to the opening size given.
2. Approximate shipping weight is 5.0 lbs./sq.ft.

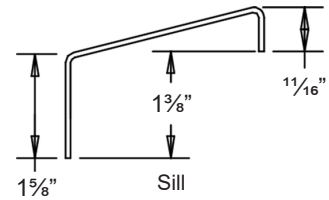
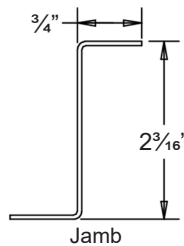
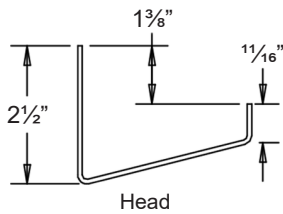
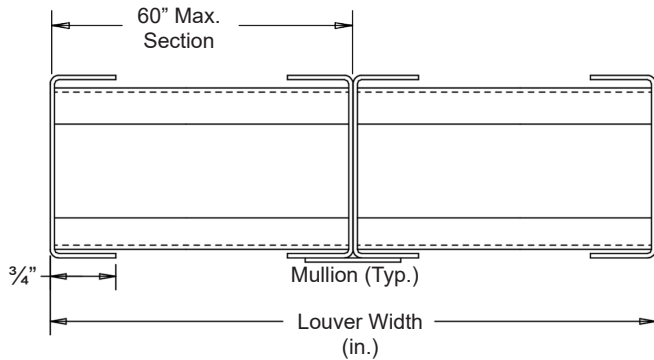
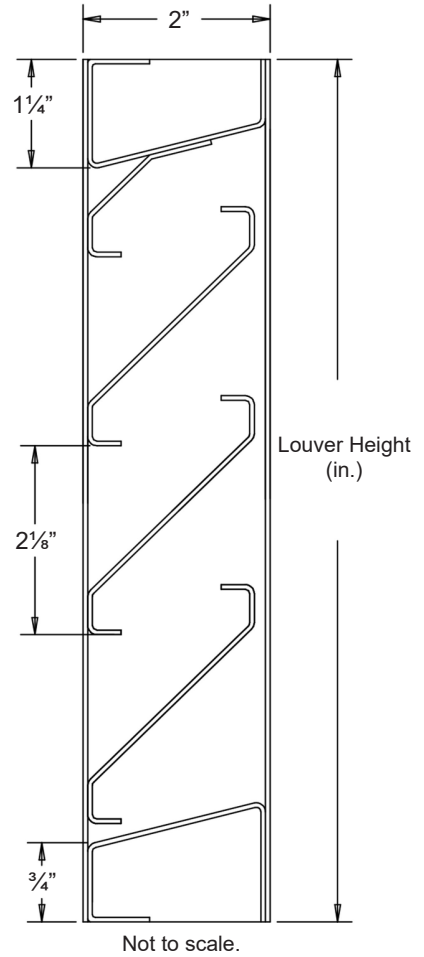

Flange Frame Available

Item #	Qty	Width	Height	Width	Height	Mullion	Type	Location	Union Made
		Opening Size		Louver Size			Screens		
Arch. / Eng. :						EDR:	ECN:	Job:	
Contractor:									
Project:						Date:	DWN:	DWG:	

In the interest of product development, Louvers & Dampers reserves the right to make changes without notice.